

VB-3005H

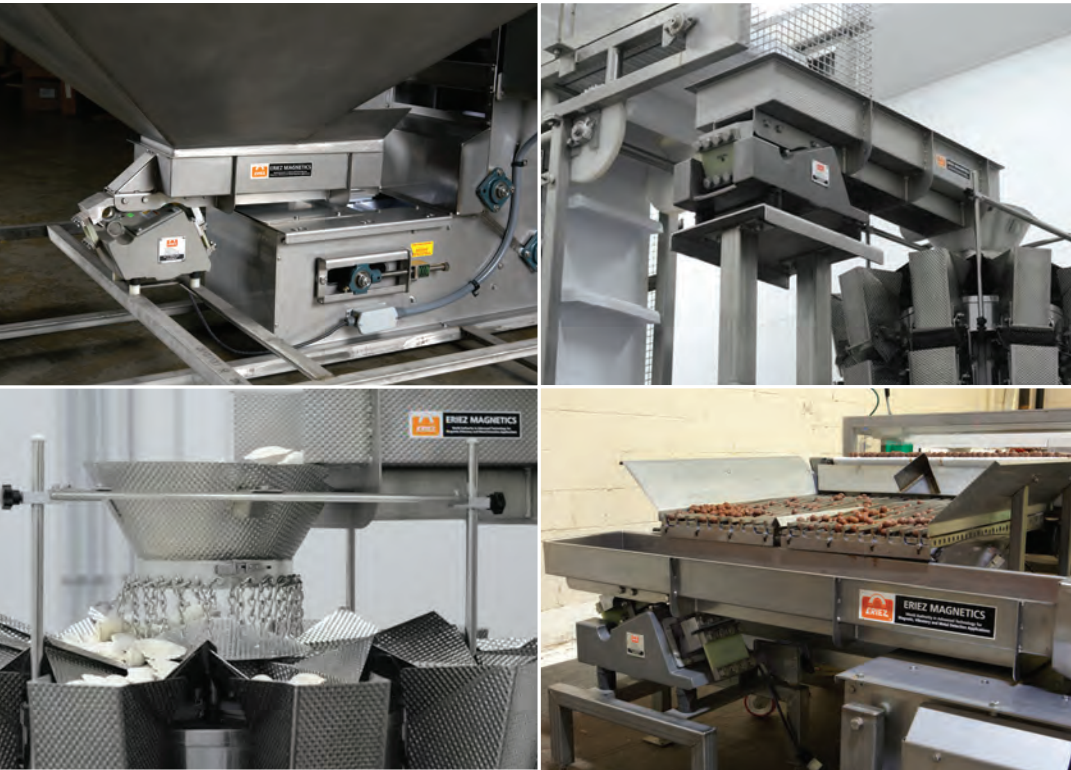

Compact Vibratory Feeders & Drives

VOLUMETRIC FEEDERS • SCREENERS • CONTROLS • SPARE PARTS



ELECTROMAGNETIC
Compact Vibratory Feeders

FEATURES

- Units easily integrate into feeder systems
- Standard and custom tray configurations
- Drives-115 or 230 volt operation (460 available for most models)
- Solid-state controls with multiple features and Nema 12, 4 and 4X enclosures available as well as chassis mount versions

RELIABLE

- Low maintenance - no rotating parts or lubrication
- No wear parts
- Energy efficient full-wave AC design on most models- up to 60% energy savings over half-wave designs

FLEXIBLE

- Efficiently feeds most products
- Models available to feed damp, tacky, light-heavy, powdery, fluffy, leafy products and most difficult materials

Table of Contents

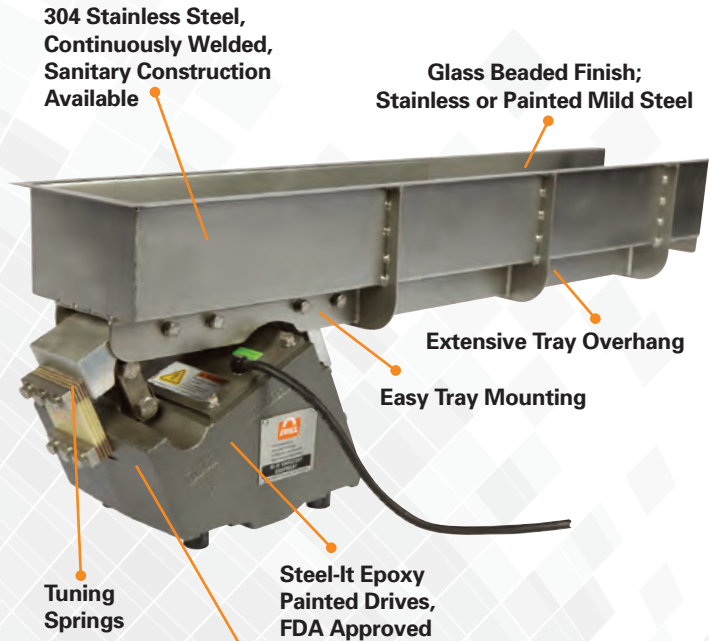

AC Electromagnetic Drives

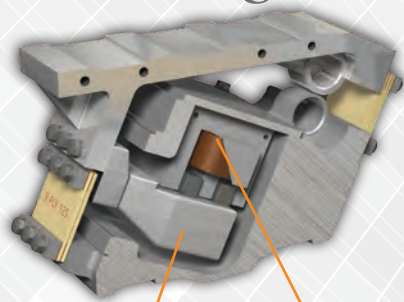

Permanent Magnet Electromagnet

DRIVE OPERATION

In the model above, the poles of the permanent magnet are shown intermeshed in the air gaps of the AC electromagnet. The polarity of the permanent magnet is fixed, while the polarity of the electromagnet alternates creating the vibratory motion. With no rotating parts or lubrication required, Eriez electromagnetic feeders are extremely reliable.

AMPLITUDE CONTROL

These drives offer 100% variable feed rate control. The amplitude of the vibration is directly controlled by the amount of AC voltage applied to the electromagnet. Simple variation of the AC voltage results in similar amplitude variation from zero to maximum.

Vibratory Feeders

pages... 4-8

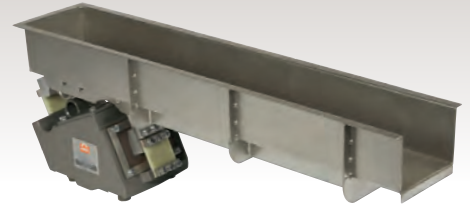

High Speed Vibratory Feeders

pages... 9-13



High Deflection Vibratory Feeders

pages... 14-16



Vibratory Screeners

page... 17

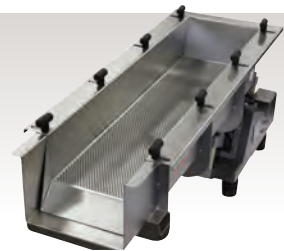

Feeder Drive Units

pages... 18-21



Volumetric Feeder Machines

pages... 22-23



Vibratory Controls

pages... 24-25

Spare Parts Kits

page... 26



Vibratory Feeders

Models A and C

These compact vibratory feeders accurately feed and control material flows at rates ranging from spoonfuls to nearly 45 tons per hour. AC operated, electromagnetic drives consume up to 60% less energy than DC drives and have no rotating parts to wear out.

Features

- Low profile
- Precise, linear feed control from 0-100% of capacity
- Standard and custom tray configurations
- Energy efficient full wave AC design on most models-60% energy savings over half-wave designs
- No wear parts
- Able to support significant material load
- 115, 230 V operation - 460 V available for most models
- 50 or 60 Hz operation - 3000 or 3600 VPM

Available

- CSA and CE approval
- Sanitary wash down designs
- Solid-state controls with multiple features and Nema 12, 4 and 4X enclosures
- Hazardous environment models (Class II, Division 1, Group F and G)
- High temperature models (130 to 300°F)



Model 6C

FOR FEEDING UP TO
1,600 LBS. (727 KG)
PER HOUR*



Power Supply	115V, 60 Cycle, Single Phase
Full Load Power Consumption	15 Watts
Full Load Power Input	.35 Amp at 115V
Control	UniCon HW
Net Feeder Weight	13.51 lb. (6.2 kg)

Specifications

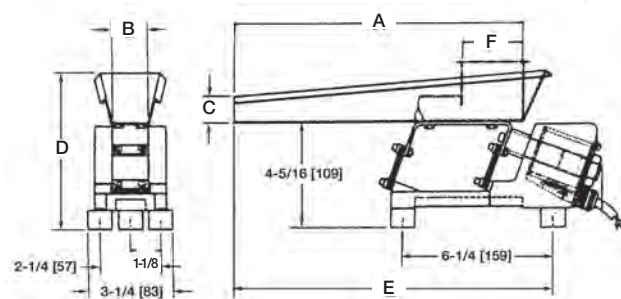

TRAY TYPE	A		B		C	
	Tray Length		Tray Width			
	in	mm	in	mm	in	mm
Narrow Flat	12	304	1-1/2	38	1-1/16	27
Wide Flat	8	203	2	51	1-1/16	27
90 Degree V	12	304	-	-	11/16	18
Small Tubular	12	304	1 (DIA.)	25	-	-

TRAY TYPE	D		E		F	
	in	mm	in	mm	in	mm
Narrow Flat	6-3/8	162	13-5/16	338	-	-
Wide Flat	6-3/8	162	9-13/16	249	-	-
90 Degree V	6-3/8	162	13-5/16	338	-	-
Small Tubular	5-13/16	148	13-5/16	338	1-3/4	44

Model 15A

FOR FEEDING UP TO
2 TONS (1.8 MT)
PER HOUR*



Power Supply	115V, 60 Cycle, Single Phase
Full Load Power Consumption	15 Watts
Full Load Power Input	0.5 Amp at 115V
Control	UniCon
Net Feeder Weight	25 lb. (11 kg)

Model 26C

FOR FEEDING UP TO
4 TONS (3.6 MT)
PER HOUR*

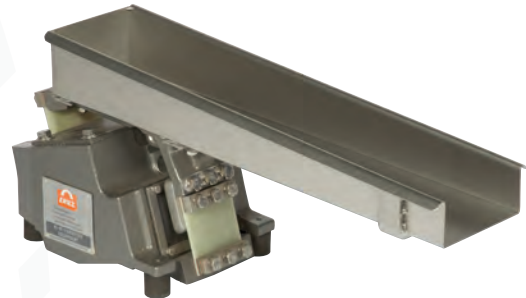

Power Supply	115V, 50-60 Cycle, Single Phase
Full Load Power Consumption	18 Watts
Full Load Power Input	1.1 Amp at 115V
Control	UniCon
Net feeder Weight	42 lb. (19 kg)

Specifications

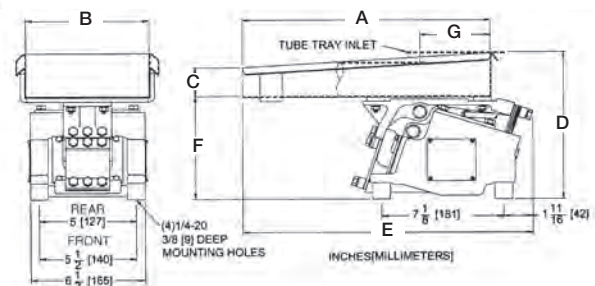
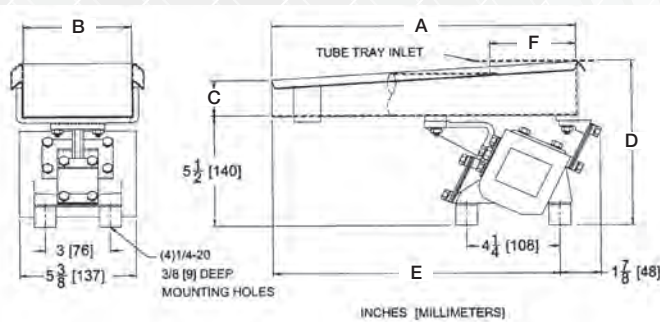

TRAY TYPE	A		B		C	
	in	mm	in	mm	in	mm
Narrow Flat	16	406	2	51	1	25
Medium Flat	20	508	4	102	1-3/4	44
Wide Flat	14	356	7	178	1-3/4	44
Small Tubular	19	483	2	51	2	50
90 Degree V	20	508	3	76	1-1/2	38
Half Round	20	508	3	76	1-1/2	38

TRAY TYPE	D		E		F	
	in	mm	in	mm	in	mm
Narrow Flat	7-1/2	191	15-1/4	387	-	-
Medium Flat	8-1/8	206	19-1/4	489	-	-
Wide Flat	8-1/8	206	13-1/4	337	-	-
Small Tubular	8	203	18-1/4	464	4	102
90 Degree V	8	203	19-1/4	489	-	-
Half Round	8	203	19-1/4	489	-	-

TRAY TYPE	A		B		C	
	in	mm	in	mm	in	mm
Narrow Flat	20	508	4	102	1-3/4	44
Medium Flat	22	559	5	127	1-3/4	44
Wide Flat	14	356	7	178	1-3/4	44
Wide Flat	20	508	7	178	1-3/4	44
90 Degree V	20	508	3	76	1-1/2	38
90 Degree V	20	508	4	102	2	51
Small Tubular	19	483	2	51	2	51
Large Tubular	19	483	3	76	3	76

TRAY TYPE	D		E		F		G	
	in	mm	in	mm	in	mm	in	mm
Narrow Flat	8-7/8	225	22-7/16	570	6-1/4	159	-	-
Medium Flat	9	229	22	559	6-1/4	159	-	-
Wide Flat	8-7/8	225	16-7/16	418	6-1/4	159	-	-
Wide Flat	9	229	20	509	6-1/4	159	-	-
90 Degree V	8-13/16	224	22-7/16	570	6-5/16	160	-	-
90 Degree V	9-3/8	237	20	509	6-3/8	161	-	-
Small Tubular	8-3/4	222	21-7/16	545	6-1/4	159	4	102
Large Tubular	10	254	19	484	6-1/4	159	6	152

Available for Class II, Division I, Group F, G Environments.

* Capacities are based on dry sand weighing 100 lb/cuft (1600 kg/cu m)

Vibratory Feeders

Model 36C FOR FEEDING UP TO 7 TONS (6.3 MT) PER HOUR*



Power Supply	115V, 60 Cycle, Single Phase
Full Load Power Consumption	38 Watts
Full Load Power Input	2.9 Amp at 115V
Control	UniCon
Net Feeder Weight	70 lb. (32 kg)

Model 48A FOR FEEDING UP TO 12 TONS (10.9 MT) PER HOUR*

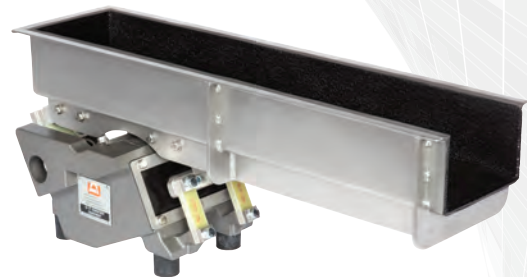

Power Supply	115V, 60 Cycle, Single Phase
Full Load Power Consumption	38 Watts
Full Load Power Input	2.0 Amp at 115V
Control	UniCon
Net feeder Weight	100 lb. (45 kg)

Specifications

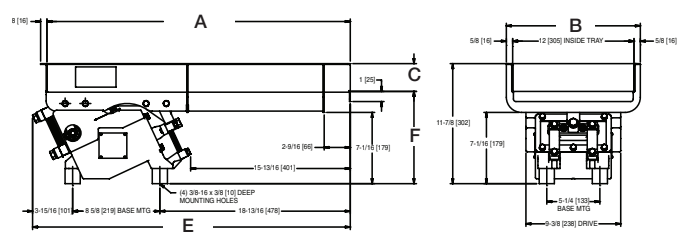
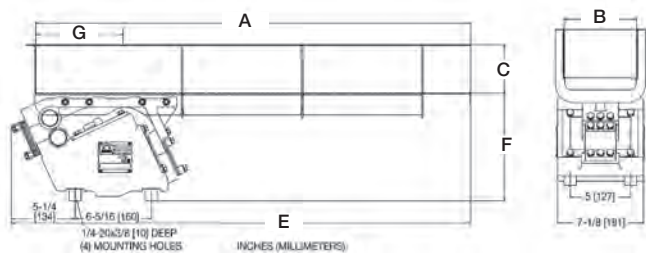

TRAY TYPE	A		B		C	
	in	mm	in	mm	in	mm
Narrow Flat	36	914	6	152	4	102
Medium Flat	30	762	8	203	4	102
Wide Flat	24	610	10	254	4	102
Small Tubular	30	762	3	76	3	76
Large Tubular	24	610	4	102	4	102

TRAY TYPE	A		B		C	
	in	mm	in	mm	in	mm
Narrow Flat	36	914	8	203	9-3/8	238
Medium Flat	30	762	12	305	9-3/8	238
Wide Flat	24	610	14	356	9-3/8	238

TRAY TYPE	D		E		F		G	
	in	mm	in	mm	in	mm	in	mm
Narrow Flat	12-15/16	328	38	966	8-15/16	226	8-15/16	226
Medium Flat	12-15/16	328	35	889	8-15/16	226	8-15/16	226
Wide Flat	12-15/16	328	31-3/4	807	8-15/16	226	8-15/16	226
Small Tubular	13-1/8	333	34-9/16	878	6	152	9 1/8	232
Large Tubular	13-1/16	332	28-5/16	719	8	203	9 1/8	232

TRAY TYPE	D		E		F	
	in	mm	in	mm	in	mm
Narrow Flat	7-1/2	191	-	-	-	-
Narrow Flat	12-1/8	308	-	-	36-5/8	930
Medium Flat	12-1/8	308	-	-	31	787
Wide Flat	12-1/8	308	-	-	27-3/8	721

Available for Class II, Division I, Group F, G Environments.

Model 46C

FOR FEEDING UP TO
15 TONS (13.6 MT)
PER HOUR*

Model 56C

FOR FEEDING UP TO
20 TONS (18.1 MT)
PER HOUR*



Power Supply	115V, 60 Cycle, Single Phase
Full Load Power Consumption	58 Watts
Full Load Power Input	4.2 Amp at 115V
Control	UniCon
Net Feeder Weight	135 lb. (61 kg)

Power Supply	115V, 60 Cycle, Single Phase
Full Load Power Consumption	75 Watts
Full Load Power Input	6.6 Amp at 115V
Control	UniCon
Net Feeder Weight	192 lb. (87 kg)

Specifications

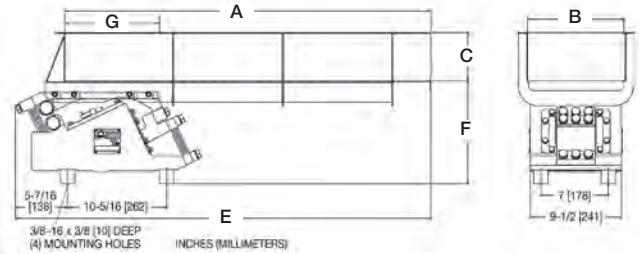
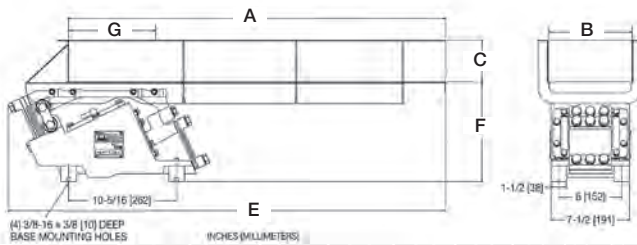

TRAY TYPE	A		B		C	
	in	mm	in	mm	in	mm
Narrow Flat	36	914	8	203	4	102
Wide Flat	30	762	12	305	4	102
Small Tubular	36	914	4	102	4	102
Large Tubular	30	762	6	152	6	152

TRAY TYPE	D		E		F		G	
	in	mm	in	mm	in	mm	in	mm
Narrow Flat	13-7/16	342	41-3/4	1061	9-7/16	240	-	-
Wide Flat	13-7/8	353	39-1/4	997	9-7/8	251	-	-
Small Tubular	15	382	38-1/8	968	10	254	8	203
Large Tubular	17	432	38-9/16	980	10	254	8	203

Available for Class II, Division I, Group F, G Environments.

TRAY TYPE	A		B		C	
	in	mm	in	mm	in	mm
Narrow Flat	38	965	10	254	4	102
Medium Flat	30	762	14	356	4	102
Wide Flat	24	610	17	432	4	102
Small Tubular	48	1219	4	102	4	102
Med. Tubular	42	1067	6	152	6	152
Large Tubular	38	965	8	203	8	203

TRAY TYPE	D		E		F		G	
	in	mm	in	mm	in	mm	in	mm
Narrow Flat	15-5/8	397	43-1/8	1096	10-5/8	270	-	-
Medium Flat	15-5/8	397	39-1/8	994	10-5/8	270	-	-
Wide Flat	14-5/8	372	29-7/16	748	10-5/8	270	-	-
Small Tubular	15-5/8	397	51-9/16	1310	10-5/8	270	8	203
Med. Tubular	18-1/8	460	45-3/4	1162	12-1/8	270	12	304
Large Tubular	20-3/8	518	41-7/16	1053	12-5/8	276	16	406

Available for Class II, Division I, Group F, G Environments.

* Capacities are based on dry sand weighing 100 lb/cuft (1600 kg/cu m)

Vibratory Feeders

Model 66C FOR FEEDING UP TO 25 TONS (22.7 MT) PER HOUR*



Power Supply	115, 60 Cycle, Single Phase
Full Load Power Consumption	90 Watts
Full Load Power Input	8.25 Amp at 115V
Control	UniCon
Net Feeder Weight	290 lb. (142 kg)

Model 76C FOR FEEDING UP TO 43 TONS (40 MT) PER HOUR*



The 76 Series feeders were developed to address the increased material capacities required by manufacturers, bucket elevators, scale systems and dryers. The 76 series provides the larger trays, ease of integration and higher capacities to handle challenging applications.

Power Supply	230V, 50 or 60 cycle, Single Phase 460V, 50 or 60 cycle, Single Phase
Full Load Power Consumption	240 Watts
Full Load Power Input	12 Amps
Control	UniCon/UniCon HC
Net Feeder Weight	740 lb. (354 kg)

Specifications

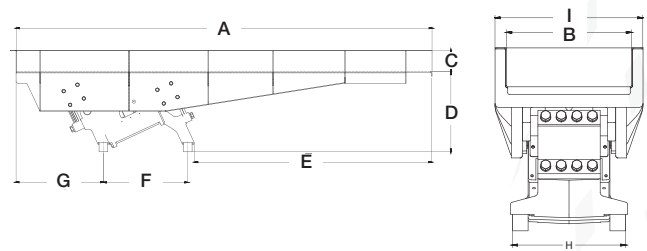
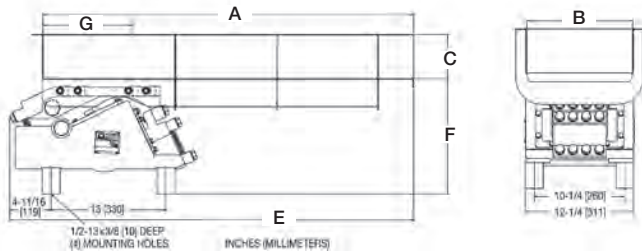

TRAY TYPE	A		B		C	
	Tray Length		Tray Width			
	in	mm	in	mm	in	mm
Narrow Flat	42	1067	12	305	5	127
Medium Flat	36	914	14	356	5	127
Wide Flat	30	762	16	406	5-1/2	140

TRAY TYPE	D		E		F		G	
	in	mm	in	mm	in	mm	in	mm
Narrow Flat	18	458	45-3/4	1163	13	330	-	-
Medium Flat	18	458	43-3/4	1112	13	330	-	-
Wide Flat	17-1/32	433	41-3/8	1051	13-1/32	330	-	-

Available for Class II, Division I, Group F, G Environments.

* Capacities are based on dry sand weighing 100 lb/cuft (1600 kg/cu m)

TRAY TYPE	A		B		C		D	
	Tray Length		Tray Width		Tray Depth			
	in	mm	in	mm	in	mm	in	mm
Narrow Long	108	2743	12	305	5	127	18-13/16	478
Narrow Long	96	2438	16	406	5	127	18-13/16	478
Narrow Long	96	2438	18	457	5	127	18-13/16	478
Wide Long	84	2133	20	508	5	127	18-13/16	478
Wide Long	84	2133	24	610	5	127	18-13/16	478

TRAY TYPE	E		F		G		H		I	
	in	mm	in	mm	in	mm	in	mm	in	mm
Narrow Long	61-11/16	1567	19-1/2	495	23-13/16	605	12-1/2	318	15	381
Narrow Long	53-3/16	1351	19-1/2	495	20-5/16	516	12-1/2	318	19	483
Narrow Long	53-3/16	1351	19-1/2	495	20-5/16	516	12-1/2	318	21	533
Wide Long	46-11/16	1186	19-1/2	495	14-13/16	376	12-1/2	318	23	584
Wide Long	46-11/16	1186	19-1/2	495	14-13/16	376	12-1/2	318	27	686

High Speed Vibratory Feeders



Model HS

Eriez AC operated Model HS High-Speed Feeders have been designed for the high speed feeding of light, bulky materials. They provide greater economy and efficiency in feeding and filling, and are ideal for use in conjunction with weigh scale and packaging machines. The units are light and functional and can be installed easily in small spaces.

Model HS Feeders deliver up to .090 in. (2.3 mm) tray displacement at 3600 VPM. Increasing feed rates by 25%-40% and are ideal for rapid cycling applications.

- 25%-40% increase in feed rates
- Rapid on-off cycling
- AC Operation - 60% more efficient than DC models
- Revolutionary Tuning - accommodates a wide range of trays
- Spring System tolerates high deflections and rapid cycling without early failure
- Quick Stopping - rapid de-energizing elastomeric spring

Feed Rates

Feed rate is easily adjusted by Eriez' variable solid-state controller.

Spring System

The spring system consists of leaf springs and an elastomeric torsion spring having high damping properties designed so that high deflections can be tolerated without danger of early failure, as well as making it possible to drive the moving assembly at high deflections with maximum stability and minimum input power.

Quick-Stopping

These springs have quick-stopping characteristics due to the rapid decline of vibratory energy when the unit is de-energized, making them ideal for packaging where overruns of material cannot be tolerated.

Simple Tuning

Easily adaptable for a greater variety of tray sizes and weights. Tuning, when required, is accomplished through simple replacement of an easily accessible glass fiber tuning spring. No other adjustment is necessary. Simple, clean lines with no pockets and crevices reduce foreign matter accumulation.

Trays are of welded construction and available in mild steel or 304 stainless. Rubber isolators are standard, coil spring isolators are also available.



High Speed Vibratory Feeders

Model HS-10

FOR FEEDING UP TO
80 CU FT (2.3 M3)
PER HOUR



Model HS-26

FOR FEEDING UP TO
120 CU FT (3.4 M3)
PER HOUR



Power Supply	115V, 60 Cycle, Single Phase
Full Load Power Consumption	40 Watts
Full Load Power Input	1.0 Amp at 115V
Control	Model FT-115
Net Feeder Weight	25 lb. (11 kg)

Power Supply	115V, 60 Cycle, Single Phase
Full Load Power Consumption	37 Watts
Full Load Power Input	1.2 Amp at 115V
Control	Model FT-115
Net Feeder Weight	42 lb. (19 kg)

Specifications

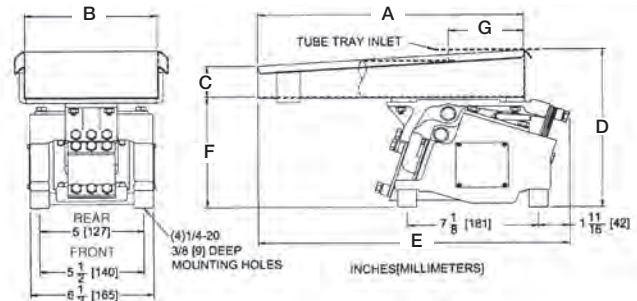
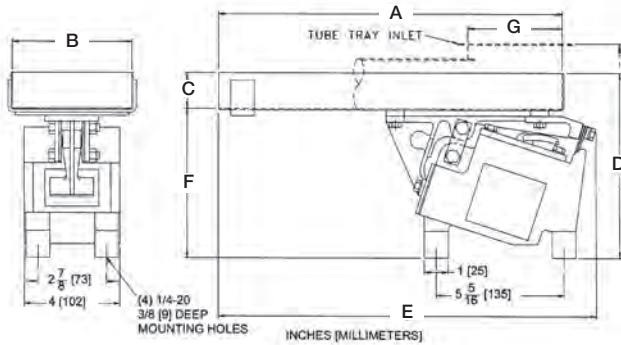

TRAY TYPE	A		B		C	
	Tray Length		Tray Width			
	in	mm	in	mm	in	mm
Narrow Flat	18	457	3	76	1	25
Wide Flat	12	305	6	152	1-1/4	32
90 Degree V	18	457	3	76	1	25
Half Round	18	457	3	76	1-1/2	38
Tubular	17	432	3	76	2	51

TRAY TYPE	A		B		C	
	Tray Length		Tray Width			
	in	mm	in	mm	in	mm
Narrow Flat	20	508	4	102	1-3/4	44
Medium Flat	22	559	5	127	1-3/4	44
Wide Flat	14	356	7	178	1-3/4	44
Wide Flat	20	508	7	178	1-3/4	44
90 Degree V	20	508	3	76	1-1/2	38
90 Degree V	20	508	4	102	2	51
Small Tubular	19	483	2	51	2	51
Large Tubular	19	483	3	76	3	76

TRAY TYPE	D		E		F		G	
	in	mm	in	mm	in	mm	in	mm
Narrow Flat	7-1/4	184	19-7/16	494	6-1/4	159	-	-
Wide Flat	7-1/2	191	14-1/2	368	6-1/4	159	-	-
90 Degree V	8-5/16	211	19-7/16	494	6-5/16	161	-	-
Half Round	7-3/8	187	19-3/4	502	5-7/8	149	-	-
Tubular	8-1/4	210	18-3/4	476	6-1/4	159	4	102

TRAY TYPE	D		E		F		G	
	in	mm	in	mm	in	mm	in	mm
Narrow Flat	8-7/8	225	22-3/8	568	6-1/4	159	-	-
Medium Flat	9	229	22	559	6-1/4	159	-	-
Wide Flat	8-7/8	225	16-3/8	416	6-1/4	159	-	-
Wide Flat	9	229	20	509	6-1/4	159	-	-
90 Degree V	8-13/16	224	22-3/8	568	6-5/16	160	-	-
90 Degree V	9-3/8	237	20	509	6-3/8	161	-	-
Small Tubular	8-3/4	222	21-3/8	543	6-1/4	159	4	102
Large Tubular	10	254	19	484	6-1/4	159	6	152

Model HS-36

FOR FEEDING UP TO
200 CU FT (5.7 M³)
PER HOUR



Power Supply	115V, 60 Cycle, Single Phase
Full Load Power Consumption	75 Watts
Full Load Power Input	2.2 Amp at 115V
Control	Model N12-UN-6A
Net Feeder Weight	70 lb. (32 kg)

Model HS-42

FOR FEEDING UP TO
200 CU FT (5.7 M³)
PER HOUR

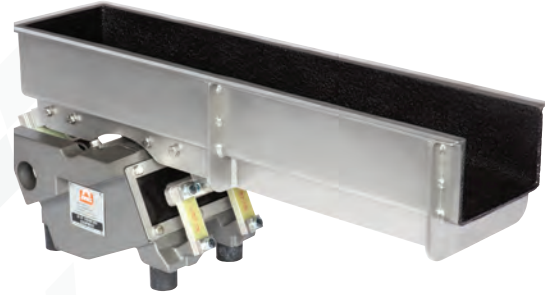

Power Supply	115V, 60 Cycle, Single Phase
Full Load Power Consumption	38 Watts
Full Load Power Input	2.0 Amp at 115V
Control	Model FT-115
Net Feeder Weight	100 lb. (45 kg)

Specifications

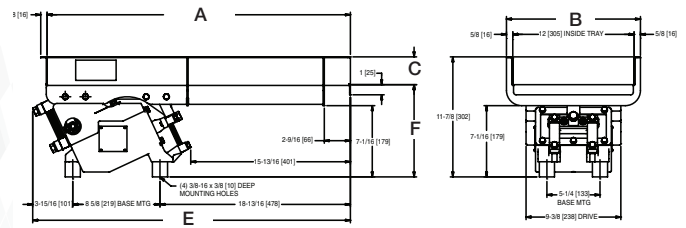
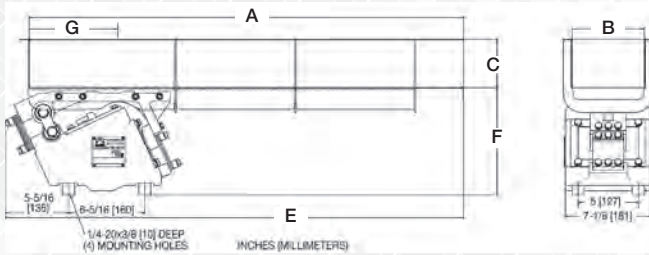

TRAY TYPE	A		B		C	
	Tray Length		Tray Width		Tray Width	
	in	mm	in	mm	in	mm
Narrow Flat	36	914	6	152	4	102
Medium Flat	30	762	8	203	4	102
Wide Flat	24	610	10	254	4	102
Small Tubular	30	762	3	76	3	76
Large Tubular	24	610	4	102	4	102

TRAY TYPE	A		B		C	
	Tray Length		Tray Width		C	
	in	mm	in	mm	in	mm
Narrow Flat	36	914	8	203	9-3/8	238
Medium Flat	30	762	12	305	9-3/8	238
Wide Flat	24	610	14	356	9-3/8	238

TRAY TYPE	D		E		F	
	in	mm	in	mm	in	mm
	Narrow Flat	12-15/16	328	30-1/16	963	8-15/16
Medium Flat	12-15/16	328	35	887	8-15/16	226
Wide Flat	12-15/16	328	31-3/4	753	8-15/16	226
Small Tubular	13-1/8	333	34-9/16	878	9-1/8	232
Large Tubular	14-1/16	357	28-9/16	726	9-1/8	232

TRAY TYPE	D		E		F	
	in	mm	in	mm	in	mm
	Narrow Flat	7-1/2	191	-	-	-
Narrow Flat	12-1/8	308	-	-	36-5/8	930
Medium Flat	12-1/8	308	-	-	31	787
Wide Flat	12-1/8	308	-	-	27-3/8	721

Available for Class II, Division I, Group F, G Environments.

High Speed Vibratory Feeders

Model HS-46

FOR FEEDING UP TO
365 CU FT (10.3 M3)
PER HOUR



Model HS-56

FOR FEEDING UP TO
400 CU FT (11.3 M3)
PER HOUR



Power Supply	115V, 60 Cycle, Single Phase
Full Load Power Consumption	107 Watts
Full Load Power Input	2.4 Amp at 115V
Control	Model N12-UN-6A
Net Feeder Weight	135 lb. (61 kg)

Power Supply	115V, 60 Cycle, Single Phase
Full Load Power Consumption	108 Watts
Full Load Power Input	2.6 Amp at 115V
Control	Model N12-UN-6A
Net Feeder Weight	192 lb. (87 kg)

Specifications

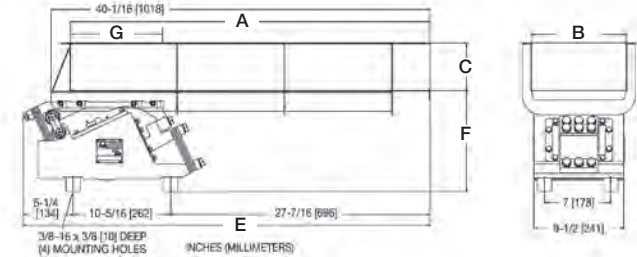
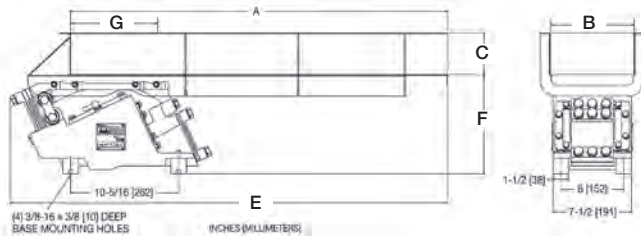

TRAY TYPE	A		B		C	
	in	mm	in	mm	in	mm
Narrow Flat	36	914	8	203	4	102
Wide Flat	30	762	12	305	4	102
Small Tubular	36	914	4	102	4	102
Large Tubular	30	762	6	152	6	152

TRAY TYPE	A		B		C	
	in	mm	in	mm	in	mm
Narrow Flat	38	965	10	254	5	127
Medium Flat	30	762	14	356	5	127
Wide Flat	24	610	17	432	4	102
Small Tubular	48	1219	4	102	4	102
Med. Tubular	42	1067	6	152	6	152
Large Tubular	38	965	8	203	8	203

TRAY TYPE	D		E		F		G	
	in	mm	in	mm	in	mm	in	mm
Narrow Flat	13-7/16	342	41-3/4	1061	9-7/16	240	-	-
Wide Flat	13-7/8	353	39-3/16	995	9-7/8	251	-	-
Small Tubular	15	382	38-1/8	968	10	254	8	203
Large Tubular	17-1/2	445	38-9/16	980	10	254	8	203

TRAY TYPE	D		E		F		G	
	in	mm	in	mm	in	mm	in	mm
Narrow Flat	15-5/8	397	43	1092	10-5/8	270	-	-
Medium Flat	15-5/8	397	39	990	10-5/8	270	-	-
Wide Flat	14-5/8	397	29-7/16	748	10-5/8	270	-	-
Small Tubular	15-5/8	397	51-9/16	1310	10-5/8	270	8	203
Med. Tubular	18-1/8	460	45-9/16	1154	10-5/8	270	12	304
Large Tubular	20-3/8	518	41-7/16	1053	10-7/8	276	16	406

Available for Class II, Division I, Group F, G Environments.

Available for Class II, Division I, Group F, G Environments.

Model HS-66

FOR FEEDING UP TO
600 CU FT (17 M³)
PER HOUR

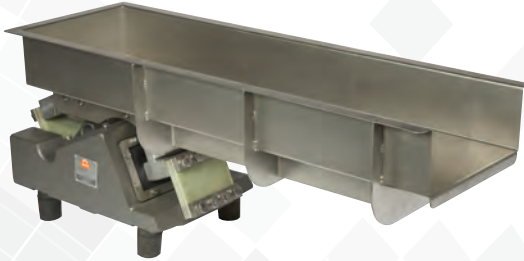

Power Supply	115V, 60 Cycle, Single Phase
Full Load Power Consumption	104 Watts
Full Load Power Input	3.2 Amp at 115V
Control	Model N12-UN-6A
Net Feeder Weight	290 lb. (132 kg)

Model HS-76

FOR FEEDING UP TO
1000 CU FT (28 M³)
PER HOUR



Power Supply	230V, 50 or 60 Cycle, Single Phase 460V, 50 or 60 Cycle, Single Phase
Full Load Power Consumption	280 Watts
Full Load Power Input	15 Amps
Control	Model UN/230-15A
Net Feeder Weight	805 lb. (380 kg)

Specifications

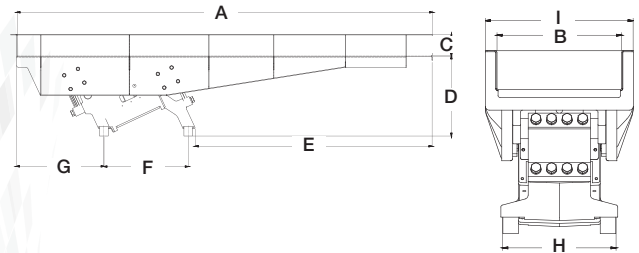
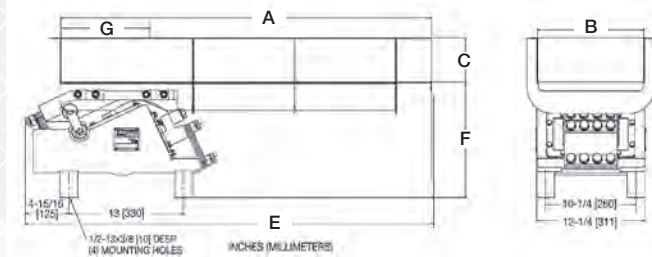

TRAY TYPE	A		B		C	
	Tray Length		Tray Width		Tray Depth	
	in	mm	in	mm	in	mm
Narrow Flat	42	1067	12	305	4	102
Medium Flat	36	914	14	356	4	102
Wide Flat	30	762	16	406	5-1/2	140

TRAY TYPE	D		E		F		G	
	in	mm	in	mm	in	mm	in	mm
Narrow Flat	18-1/2	470	47	1194	13	330	-	-
Medium Flat	18-1/2	470	44-1/2	1130	13	330	-	-
Wide Flat	18-1/2	470	41-3/8	1051	13	330	-	-

Available for Class II, Division I, Group F, G Environments.

TRAY TYPE	A		B		C		D	
	Tray Length		Tray Width		Tray Depth		Discharge Height	
	in	mm	in	mm	in	mm	in	mm
Narrow Long	108	2743	12	305	5	127	18-13/16	478
Narrow Long	96	2438	16	406	5	127	18-13/16	478
Narrow Long	96	2438	18	457	5	127	18-13/16	478
Wide Long	84	2133	20	508	5	127	18-13/16	478
Wide Long	84	2133	24	610	5	127	18-13/16	478

TRAY TYPE	E		F		G		H		I	
	in	mm	in	mm	in	mm	in	mm	in	mm
Narrow Long	61-11/16	1567	19-1/2	495	23-13/16	605	12-1/2	318	15	381
Narrow Long	53-3/16	1351	19-1/2	495	20-5/16	516	12-1/2	318	19	483
Narrow Long	53-3/16	1351	19-1/2	495	20-5/16	516	12-1/2	318	21	533
Wide Long	46-11/16	1186	19-1/2	495	14-13/16	376	12-1/2	318	23	584
Wide Long	46-11/16	1186	19-1/2	495	14-13/16	376	12-1/2	318	27	686

High Deflection Vibratory Feeders

Model HD & HDC

Model HD (High Deflection) Vibratory Feeders combine higher deflection of up to 3/16-inch (4.8 mm) and the lower frequency (30 cps) advantages of a mechanical feeder with the trouble-free service of an electromagnetic feeder.

- AC Operation - 75% more efficient than DC models
- Revolutionary Tuning - accommodates a range of trays
- Spring System tolerates high deflections without early failure
- Quick Stopping - elastomeric spring rapid de-energizing.

Eriez Model HD Feeders easily handle powders and leafy products that normally could not be fed in an electromagnetic feeder. Feed rates of up to 80 ft/min (24 m/min) are possible for products with a bulk density less than 10 lb/ft³ (.16 gm/cc).

Model HD-C higher amplitude and 30 cps operation accommodates higher material loads.

The patented electromagnetic drive uses rare earth magnetic technology to produce a large displacement and low power consumption (25% of normal electromagnetic drives). This revolutionary drive has an operating frequency of 30 Hz and imitates the motion of a mechanical vibrating feeder with the control of an electromagnetic feeder.

All units are enclosed making them dust and moisture resistant. Dust-tight and epoxy-coated units are available. Epoxy-encapsulated coil and magnet eliminate coil movement, extending trouble-free coil life. Fiberglass springs give long spring life and are not subject to corrosion. Units are base mounted, and the feeder base comes with rubber isolation mounts. Trays are available in mild steel and stainless steel.

Standard control for HD Feeders is Eriez' N12G30Hz-115 solid state control which varies the feed rate from zero to 100% of capability. This control is housed in an NEMA 12 Type enclosure to ensure years of trouble-free service.

The elastomeric torsion spring on HD models provides quick-stopping characteristics and protects the fiberglass springs from damage due to overstressing.

Model HD-36 & HD-36C

FOR FEEDING UP TO
150 CU FT (8.5 M3)
PER HOUR

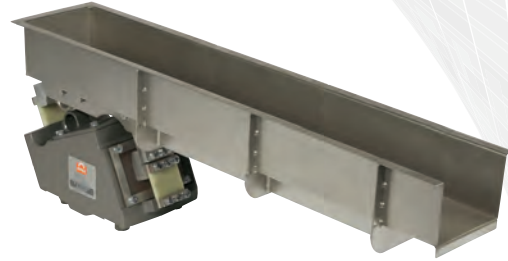

	HD-36	HD-36C
Power Supply	115V, 40 Cycle, Single Phase	115V, 40 Cycle, Single Phase
Full Load Power Consumption	71 Watts	38 Watts
Full Load Power Input	2.5 Amps	2.9 Amps
Control	Model N12G40Hz-115	
Net Feeder Weight	120 lb. (54 kg)	

Available for 115 or 230 V operation

Specifications

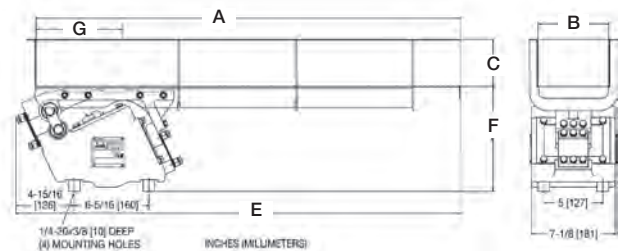

TRAY TYPE	A Tray Length		B Tray Width		C	
	in	mm	in	mm	in	mm
Narrow Flat	36	914	6	152	4	102
Medium Flat	30	762	8	203	4	102
Wide Flat	24	610	10	254	4	102
Small Tubular	30	762	3	76	3	76
Large Tubular	24	610	4	102	4	102

TRAY TYPE	D		E		F		G	
	in	mm	in	mm	in	mm	in	mm
Narrow Flat	12-15/16	328	37-11/16	958	8-15/16	226	9	229
Medium Flat	12-15/16	328	34-11/16	882	8-15/16	226	9	229
Wide Flat	12-15/16	328	31-7/16	799	8-15/16	226	9	229
Small Tubular	13-1/16	331	34-1/4	870	6	152	9-1/16	230
Large Tubular	14-1/16	357	28-1/4	717	8	203	9-1/16	230

Available for Class II, Division I, Group F, G Environments.

Model HD-46 & HD-46C

FOR FEEDING UP TO
400 CU FT (11 M³)
PER HOUR



	HD-46	HD-46C
Power Supply	115V, 30 Cycle, Single Phase	115V, 30 Cycle, Single Phase
Full Load Power Consumption	106 Watts	58 Watts
Full Load Power Input	1.5 Amps	4.2 Amps
Control	Model N12G30Hz-115	
Net Feeder Weight	135 lb. (61 kg)	

Available for 115 or 230 V operation

Specifications

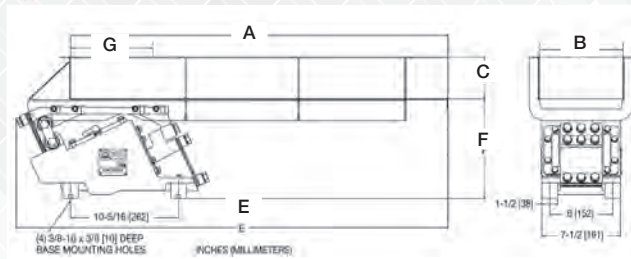

TRAY TYPE	A		B		C	
	in	mm	in	mm	in	mm
Narrow Flat	36	914	8	203	4	102
Wide Flat	30	762	12	305	4	102
Small Tubular	36	914	4	102	4	102
Large Tubular	30	762	6	152	6	152

TRAY TYPE	D		E		F		G	
	in	mm	in	mm	in	mm	in	mm
Narrow Flat	13-7/16	342	41-3/16	1046	9-7/16	240	-	-
Wide Flat	13-7/8	351	38-5/8	982	9-7/8	251	-	-
Small Tubular	14-3/16	360	37-9/16	954	9-3/16	233	8	203
Large Tubular	16-5/16	440	38-1/16	987	9-13/16	250	8	203

Available for Class II, Division I, Group F, G Environments.

Model HD-56 & HD-56C

FOR FEEDING UP TO
500 CU FT (14 M³)
PER HOUR



	HD-56	HD-56C
Power Supply	115V, 30 Cycle, Single Phase	115V, 30 Cycle, Single Phase
Full Load Power Consumption	95 Watts	75 Watts
Full Load Power Input	1.5 Amps	6.6 Amps
Control	Model N12G30Hz-115	
Net Feeder Weight	192 lb. (87 kg)	

Available for 115 or 230 V operation

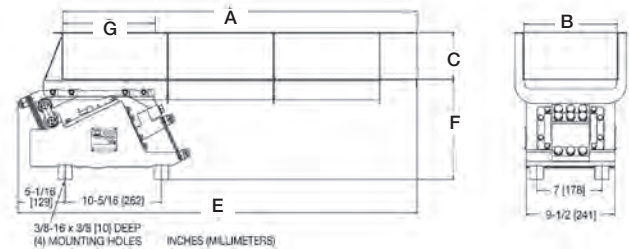

TRAY TYPE	A		B		C	
	in	mm	in	mm	in	mm
Narrow Flat	38	965	10	254	5	127
Medium Flat	30	762	14	356	5	127
Wide Flat	24	610	17	432	5	127
Small Tubular	48	1219	4	102	4	102
Med. Tubular	42	1067	6	152	6	152
Large Tubular	38	965	8	203	8	203

TRAY TYPE	D		E		F		G	
	in	mm	in	mm	in	mm	in	mm
Narrow Flat	15-5/8	397	42-13/16	1053	10-5/8	270	-	-
Medium Flat	15-5/8	397	38-13/16	1000	10-5/8	270	-	-
Wide Flat	16-1/8	410	29-7/16	748	10-5/8	270	-	-
Small Tubular	15-5/8	397	51-9/16	1310	10-5/8	270	8	203
Med. Tubular	18-1/8	460	45-1/4	1149	11-1/8	284	12	304
Large Tubular	20-3/8	518	40-15/16	1039	10-7/8	276	16	406

Available for Class II, Division I, Group F, G Environments.

High Deflection Vibratory Feeders

Model HD-66 & HD-66C

FOR FEEDING UP TO
700 CU FT (20 M3)
PER HOUR



Model HD-76C

FOR FEEDING UP TO
1400 CU FT (40 M3)
PER HOUR



	HD-66	HD-66C
Power Supply	115V, 30 Cycle, Single Phase	115V, 30 Cycle, Single Phase
Full Load Power Consumption	165 Watts	90 Watts
Full Load Power Input	2.6 Amps	8.25 Amps
Control	Model N12G30Hz-115	
Net Feeder Weight	290 lb. (142 kg)	

Power Supply	230V, 30 Cycle, Single Phase
Full Load Power Consumption	450 Watts
Full Load Power Input	12 Amps
Control	Model N12G30Hz-230V
Net Feeder Weight	740 lb. (354 kg)

Available for 115 or 230 V operation

Specifications

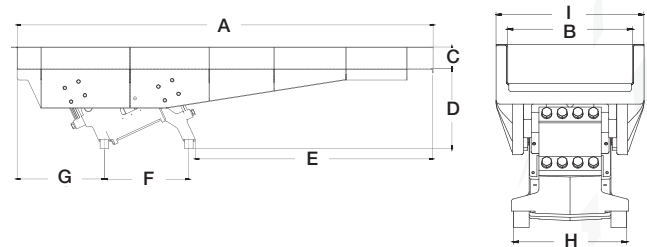
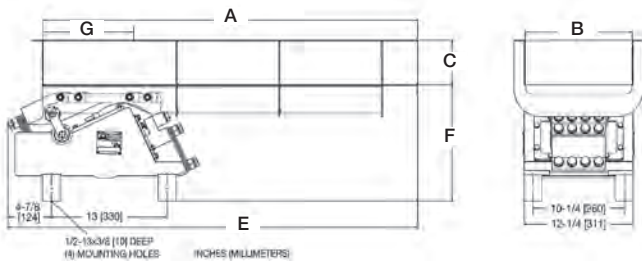

TRAY TYPE	A		B		C	
	in	mm	in	mm	in	mm
Narrow Flat	42	1067	12	305	4	102
Medium Flat	36	914	14	356	4	102
Wide Flat	30	762	16	406	5-1/2	140

TRAY TYPE	A		B		C		D	
	in	mm	in	mm	in	mm	in	mm
Narrow Long	108	2743	12	305	5	127	18-13/16	478
Narrow Long	96	2438	16	406	5	127	18-13/16	478
Narrow Long	96	2438	18	457	5	127	18-13/16	478
Wide Long	84	2133	20	508	5	127	18-13/16	478
Wide Long	84	2133	24	610	5	127	18-13/16	478

TRAY TYPE	D		E		F		G	
	in	mm	in	mm	in	mm	in	mm
Narrow Flat	18	458	45-15/16	1164	13-1/32	331	-	-
Medium Flat	18	458	43-15/16	1117	13-1/32	331	-	-
Wide Flat	18-17/32	471	41-3/8	1051	13-1/32	331	-	-

TRAY TYPE	E		F		G		H		I	
	in	mm	in	mm	in	mm	in	mm	in	mm
Narrow Long	61-11/16	1567	19-1/2	495	23-13/16	605	12-1/2	318	15	381
Narrow Long	53-3/16	1351	19-1/2	495	20-5/16	516	12-1/2	318	19	483
Narrow Long	53-3/16	1351	19-1/2	495	20-5/16	516	12-1/2	318	21	533
Wide Long	46-11/16	1186	19-1/2	495	14-13/16	376	12-1/2	318	23	584
Wide Long	46-11/16	1186	19-1/2	495	14-13/16	376	12-1/2	318	27	686

Available for Class II, Division I, Group F, G Environments.

Compact Vibratory Screeners



Model A, C, HS, HD

A and C Screeners

Custom sizes, high frequency, low amplitude screeners are ideal for fine mesh separation (4 mesh to 325 mesh). Sizes from 80 square inches (500 sq cm) to 24 sq ft (2.2 sq m) of screening area ideal for de-dusting or fine separation. Models are available for Class ii, Div. 1, Group f and G environments.

Features: Adjustable amplitude, fixed 3600 cycle frequency, no maintenance drives, and a 1 year warranty on "A" and "C" drives.

HD Model Screeners

Eriez High Deflection Screeners offer an electromagnetic design with the added benefit of high amplitude similar to a mechanical screener. Operating at a fixed 1800 vibrations per minute and approximately 3/16" displacement, makes the HD models a very flexible design that is suitable for a wide range of applications.

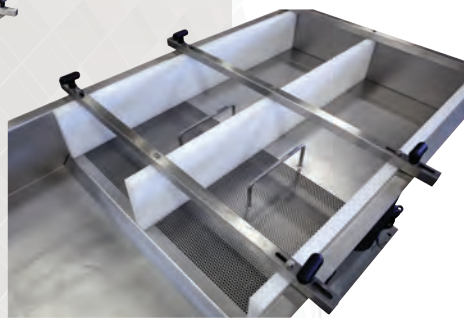
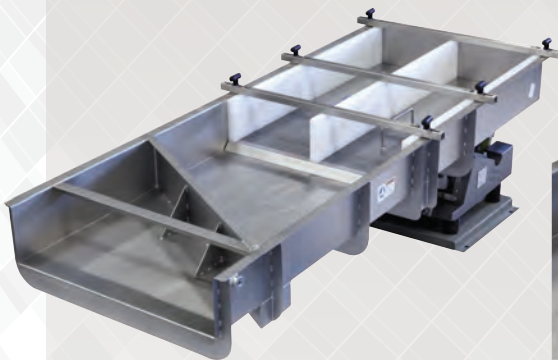

Designing for Special Application Requirements

Eriez' experience in designing unique feeders and trays for special applications means that unusual requirements can be met reliably.

Our experienced engineers, production specialists and state-of-the-art manufacturing easily handle the non-typical requirements for unique applications.



Long narrow trays can be furnished to form vibratory conveyors.



Tubular trays – part of an enclosed system used for hot, gassy or dusty products.



Feeder Drive Units

Eriez electromagnetic feeder drives are suitable for most any feeding application.

With the wide range of sizes and feeding characteristics, Eriez has drives suitable for your feeding, packaging and processing needs.

- Model A, C and HS are available for 115 or 230 volt and 50 or 60 Hz, single-phase operation
- Model HD and HDC models are available for 115 or 230 volt and 30 Hz (40 Hz for HD36 and HD36C), single-phase operation
- Some models can be provided for 460 or 575 volt operation
- Drive selection is based primarily on the tray mass to be attached to the drive and type of material handled on the feeder
- Eriez feeder drives are readily tuned by changing the leaf springs on the rear on the rear of the drive. No other tuning adjustments are necessary
- Each feeder drives comes with a rubber mounts on the bottom to best isolate the vibration from your support structures

Model 6C



Specifications

Handles trays up to 3-1/2 lb (1.6 kg) and .060" (1.5mm) tray displacement

Power Supply	115V, 60 Cycles, Single Phase
Full Load Power Consumption	15 Watts
Full Load Power Input	.35 Amp at 115V
Control	UniCon
Net Drive Weight	13.51 lb. (6.2 kg)

Dimensions

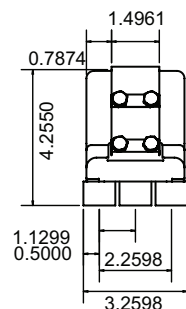
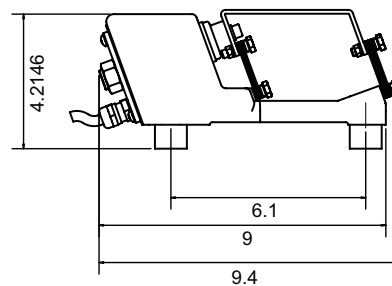
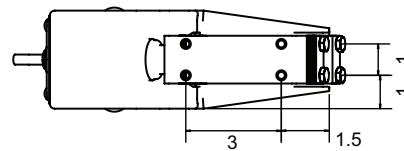

Model 15A



Handles trays up to 5-1/4 lb (2.4 kg) and .045" (1.2mm) tray displacement

Power Supply	115V, 60 Cycles, Single Phase
Full Load Power Consumption	15 Watts
Full Load Power Input	0.5 Amp at 115V
Control	UniCon
Net Drive Weight	25 lb. (11 kg)

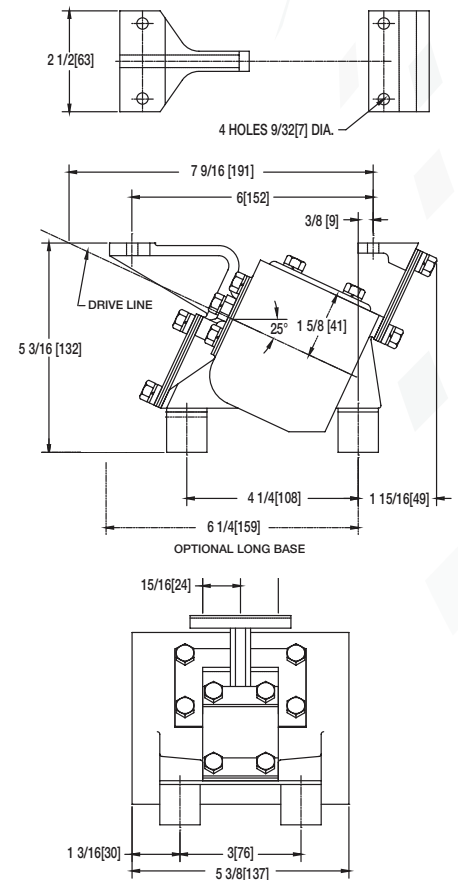

Model HS-8



Specifications

Handles trays up to 9 lb (4 kg) and .120" (3mm) tray displacement

Power Supply	115V, 60 Cycles, Single Phase	
Full Load Power Consumption	40 Watts	
Full Load Input - 115V.	1.5 Amp	
Control	Unicon	
Net Weight (without control box)	23 lb.	10.4 kg
Weight (with control box)	29 lb.	13 kb

*Typical Tray Weight 4 to 8 Lbs.

Model HS-10



Handles trays up to 4 lb (1.8 kg) and .090" (2.3mm) tray displacement

Power Supply	115V, 60 Cycles, Single Phase	
Full Load Power Consumption	40 Watts	
Full Load Power Input	1.0 Amp at 115V	
Control	Unicon	
Net Drive Weight	25 lb. (11 kg)	

26 Series



Handles trays up to 8 lb (3.6 kg)

Model	26C	HS-26
Watts	18	37
Amps*	1.1	1.2
Cycles in Hz	50-60	60
Tray Displacement	.060" (1.5mm)	.090" (2.3mm)
Power Supply and Input	115 volt, 1-Phase (230 and 460 volt available)	
Control	UniCon	
Net Weight	25 lb (11 kg)	

* Full load power consumption

Dimensions

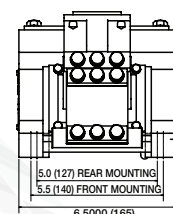
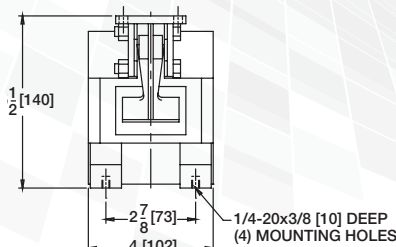
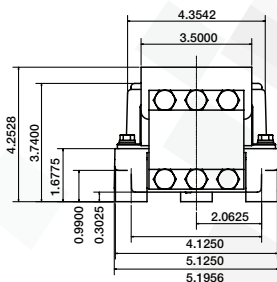
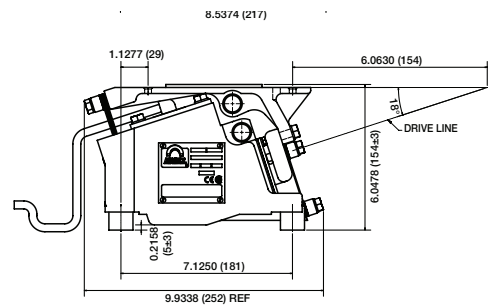
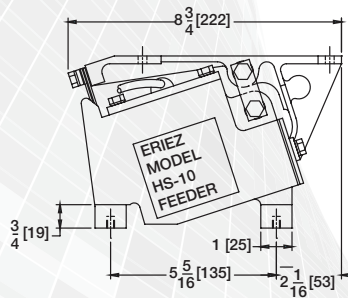
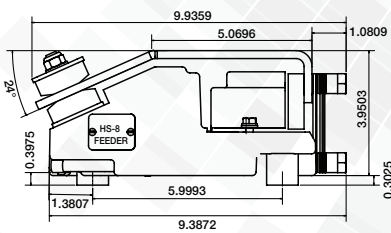
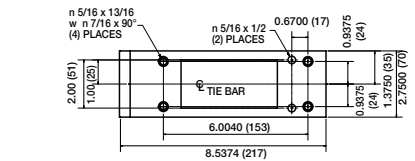
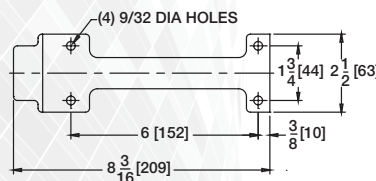
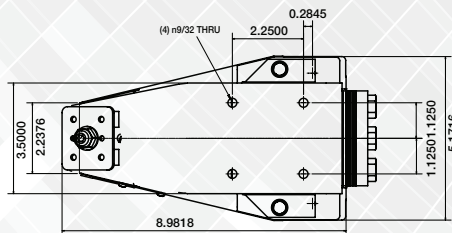

Feeder Drive Units

36 Series



Specifications

Handles tray up to 18 lb (8.2 kg)

Model	36C	HS-36	HD-36	HD-36C
Watts	38	75	71	38
Amps*	2.9	2.2	2.5	2.9
Cycles in Hz	60	60	40	40
Tray Displacement	.060" (1.5mm)	.090" (2.3mm)	.125" (3.3mm)	.125" (3.3mm)
Power Supply and Input	115 volt, 1-Phase (230 and 460 volt available)			
Control	UniCon			
Net Weight	13.51 lb (6.2 kg)			

* Full load power consumption

46 Series

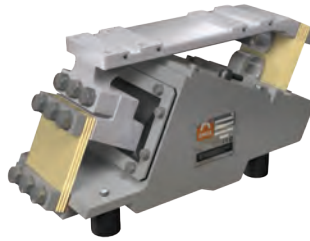

Handles tray up to 40 lb (18.1 kg)

Model	46C	HS-46	HD-46	HD-46C
Watts	58	107	106	58
Amps*	4.2	2.4	1.5	4.2
Cycles in Hz	60	60	30	30
Tray Displacement	.060" (1.5mm)	.090" (2.3mm)	.1875" (4.8mm)	.1875" (4.8mm)
Power Supply and Input	115 volt, 1-Phase (230 and 460 volt available)			
Control	Model N12-UN-6A			
Net Weight	135 lb. (61 kg)			

* Full load power consumption

Model 48A & HS-42



Handles tray up to 30 lb (13.6 kg)

Model	48A	HS-42
Watts	38	38
Amps*	2.0	2.0
Cycles in Hz	60	60
Tray Displacement	.060" (1.5mm)	.090" (2.3mm)
Power Supply and Input	115 volt, 1-Phase (230 and 460 volt available)	
Control	Model FT	
Net Weight	100 lb (45 kg)	

* Full load power consumption

Dimensions

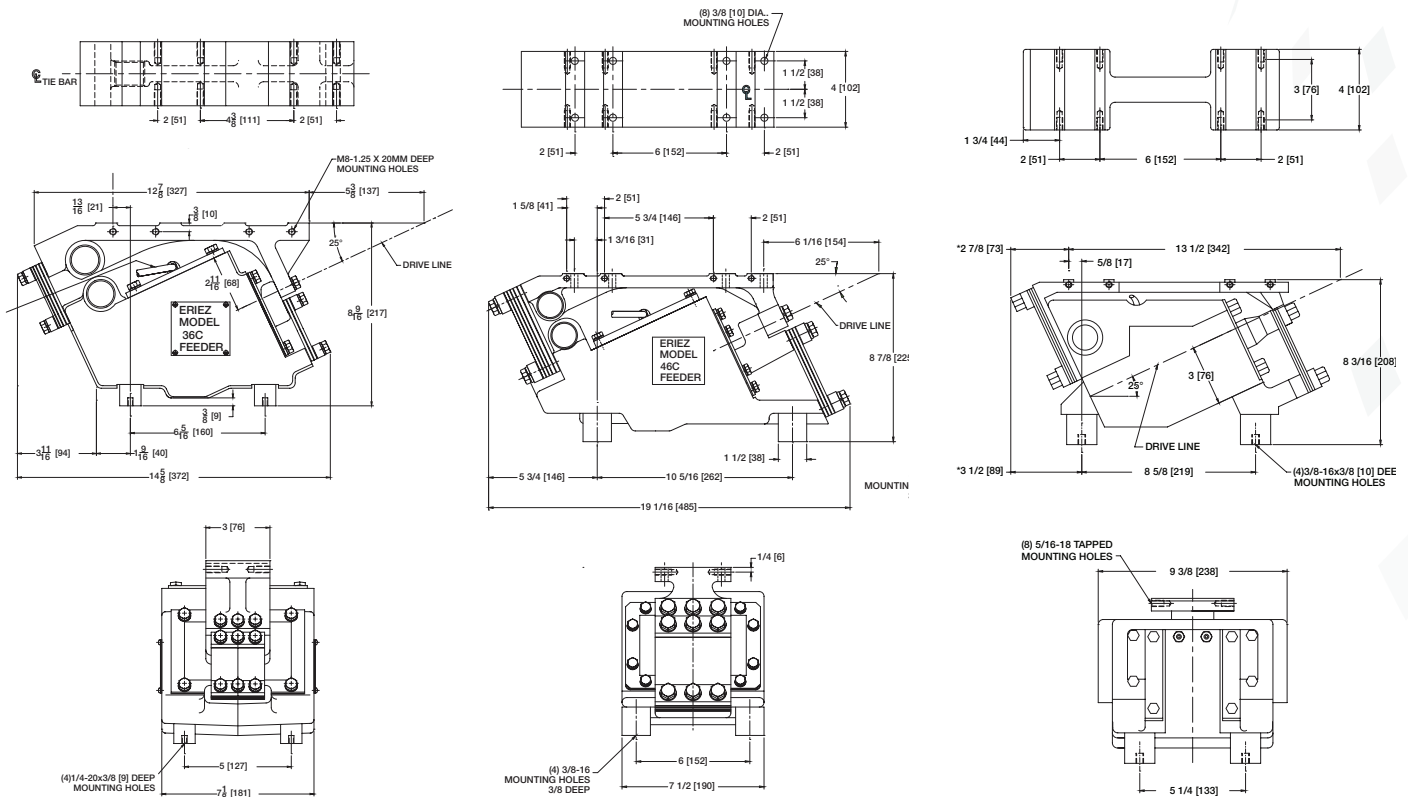

56 Series



Specifications

Handles tray up to 50 lb (22.7 kg)
HD-56, HD-56C – 60 lb (27.2 kg)

Model	56C	HS-56	HD-56	HD-56C
Watts	75	108	95	75
Amps*	6.6	2.6	1.5	6.6
Cycles in Hz	60	60	30	30
Tray Displacement	.060" (1.5mm)	.090" (2.3mm)	.1875" (4.8mm)	.1875" (4.8mm)
Power Supply and Input	115 volt, 1-Phase (230 and 460 volt available)			
Control	Model N12-UN-6A			
Net Weight	192 lb. (87 kg)			

* Full load power consumption

66 Series



Handles tray up to 60 lb (27.2 kg)
HD-66, HD-56C – 70 lb (31.8 kg)

Model	66C	HS-66	HD-66	HD-66C
Watts	90	104	165	90
Amps*	8.25	3.2	2.6	8.25
Cycles in Hz	60	60	30	30
Tray Displacement	.060" (1.5mm)	.090" (2.3mm)	.1875" (4.8mm)	.15625" (4mm)
Power Supply and Input	115 volt, 1-Phase (230 and 460 volt available)			
Control	Model N12-UN-6A			
Net Weight	290 lb. (132 kg)			

* Full load power consumption

76 Series

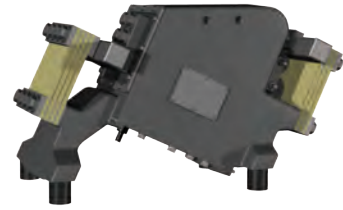

Handles tray up to 220 lb (99.8 kg)

Model	76C	HS-76	HD-76C
Watts	240	280	450
Amps*	12	15	12
Cycles in Hz	50 or 60	50 or 60	30
Tray Displacement	.060" (1.5mm)	.070" (1.8mm)	.1875" (4.8mm)
Power Supply and Input	230 or 460 volt, 1-Phase		
Control	Model UN/230-15A		
Net Weight	805 lb. (380 kg)		

* Full load power consumption

Dimensions

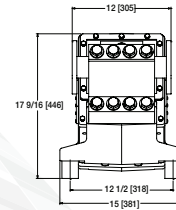
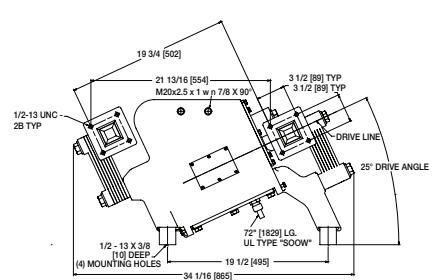
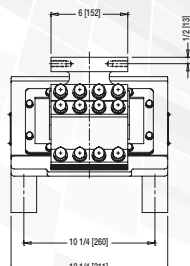
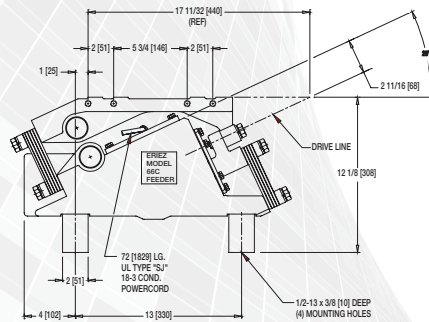
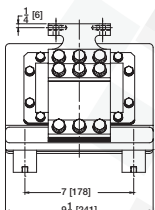
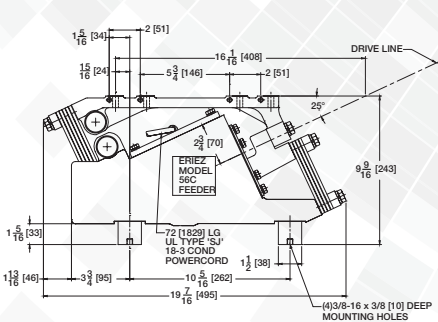
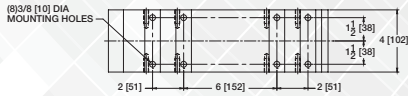

Volumatic Feeder Machines

Eriez Volumatic Feeder Machines provide the dual vibratory action of an electromagnetic feeder and bin vibrator to assure the proper flow of dry bulk material for measured discharge rates.

These one-piece, compact, rugged assemblies are ideal for use in conjunction with weigh scales, packaging and bagging equipment, small batch operations, and where additive feeding is being performed either continuously or intermittently.

Each Volumatic Feeder Machine has been designed in size, shape and vibratory action to give you the most efficient precision feeding possible. Models are available in two sizes, with variable feed rates ranging from a few pounds to 15 tons per hour.

Operating Benefits

Positive control of feed, which is critical to packaging and bagging operations, is assured by Eriez ideal integration of the feeder and hopper. All models are available for dusty locations—and as specially constructed units for installation in those areas where Class II, Group G equipment is normally used.

All models are furnished with compact, maintenance-free solid-state controls either mounted to the frame or remotely located.

Entirely Enclosed Unit

The Vibratory Feeders and Bin Vibrators used in these Feeder Machines are entirely enclosed. The feeder is so designed that the drive elements are completely protected against damage or decreased efficiency due to contamination by moisture and foreign materials.

Uniformity of Feed

The feeders are designed to produce the most uniform feed possible, consistent with the wide variety of existing field applications. They provide instant starts and stops with a minimum of product carry-over.

Operation

The adjustable spout at the bottom of the hopper can be adjusted as required to obtain the optimum depth of flow. Once this has been established and the adjustable spout secured, the best feed and vibration rates of the feeder and the hopper vibrator can be obtained by adjusting the controllers.

Timing and/or dual feeder control functions can be obtained with special controllers designed to provide such functions.



Special Feeder Machines



Model VFM 15-1-20

FOR FEEDING UP TO
2 TONS (1.9 MT)
PER HOUR

1 cu ft (.03 m3) Conical Polyethylene Hopper
(Food Grade Material)
Model 15A w/4 x 20 (100 x 500 mm)
M.S. Tray
20N Bin Vibrator
NEMA12 Unicon Control
Capacity 40 cu ft/hr (1.13 m3/hr)
of Dry Granular Material
Weight Approximately 75 lbs (34 kg)

Options Available

1 cu ft (.03 m3) Polyethylene Extension Rings
Rectangular Mild Steel or Stainless Steel Hopper
Stainless Steel Tray
Head Load Deflector
Dual Rate Controls and Timers
Covers

Dimensions

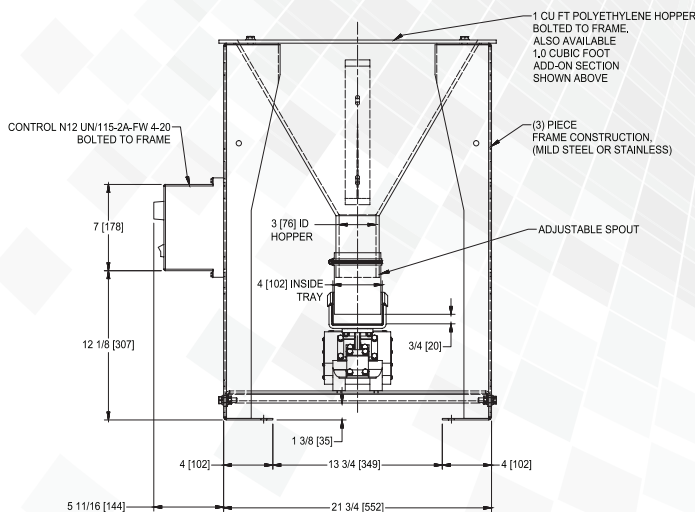
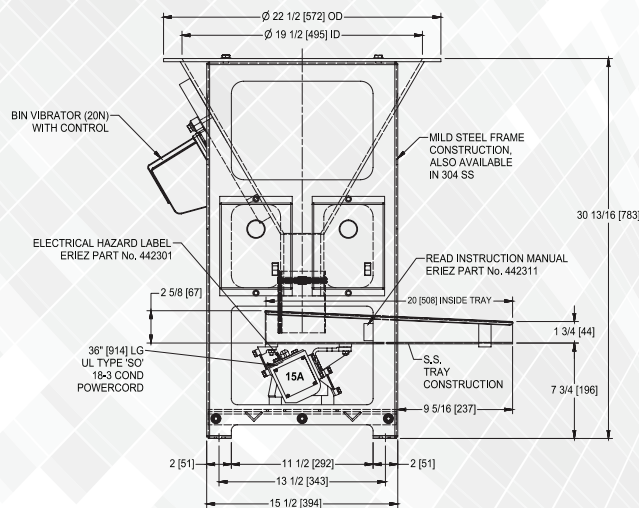

Model VFM 56-4-30

FOR FEEDING UP TO
12 TONS (10.9 MT)
PER HOUR

4 cu ft (.12 m3) Conical Polyethylene Hopper
Model 56C w/10 x 38 (254 x 965 mm) M.S. Tray
30N Bin Vibrator
NEMA 12 Unicon Control
Capacity 80 cu ft/hr (2.4 m3/hr) of Dry Granular Material
Weight Approximately 750 lbs (340 kg)

Options Available

2 cu ft (.06 m3) Polyethylene Extension Rings
Rectangular Mild Steel or Stainless Steel Hopper
Stainless Steel Tray
Head Load Deflector
Dual Rate Controls and Timers
Covers

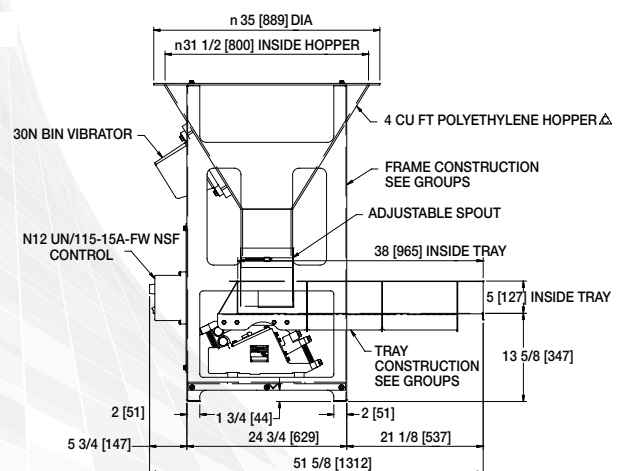
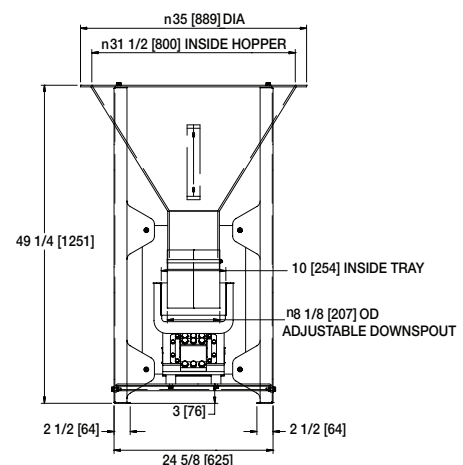

Vibratory Controls

Eriez controls accommodate the vast majority of industry applications. Eriez' full or half wave operation capability allows a plant to operate one control while competitive units provide half wave operation only.

In addition to the three control series presented here, Eriez can modify or custom design an electromagnetic feeder control to suit your specific application.



SOLID STATE CONTROLS

Control Model	Voltage	Amperage	Enclosure NEMA Type	DC/Analog Signal Capable	Closed Loop Option	Bias / Gain	Manual Adjustment	Full or Half Wave Capable	Certifications			
									CE	CUL	UL	ESA*
UniCon	115 or 230	2 to 15	N12 / IP54	•		•	Pot	•	•	•		
UniCon	115 or 230	2 to 15	Chassis	•		•	Pot	•				
UniCon HC	115 or 575	15 to 40	N4	•	•	•	Pot	•	•	•		
UniCon HC	115 or 575	15 to 40	Chassis	•	•	•	Pot	•	•	•		
G30 Hz	115 or 230	12	N12 / IP54	•	•	•	Touch Pad	•	•			•
G40 Hz	115 or 230	12	N12 / IP54	•	•	•	Touch Pad	•	•			•
G50 Hz	115 or 230	12	N12 / IP54	•	•	•	Touch Pad	•	•			•
G60 Hz	115 or 230	12	N12 / IP54	•	•	•	Touch Pad	•	•			•
G30 Hz HW	115 or 230	12	N12 / IP54	•	•	•	Touch Pad	•	•			•
All G Series	115 or 230	15	N4X	•	•	•	Touch Pad	•	•			
All G Series	115 or 230	15	Chassis	•	•	•	Touch Pad	•	•			

* ESA certification upon request

UniCon Control

FEATURES:

- Easy to use, economical, variable speed control
- Rotary dial controls speed and feed rate
- Chassis mount, NEMA 12 (IP54) enclosure standard
- Operates on 115 or 240 volts
- Rated from 2 to 15 amps at 115 volts and 1 to 15 amps at 240 volts
- Includes bias and gain internal pots to set the operating (displacement) range of feeder. Sets span of the pot on lid
- Accepts 4-20 MA or 0-10 VDC signals
- Include interlock for remote on/off
- Full wave and Half wave capable
- NEMA 12 version: UL, CUL, and CE tagged; Chassis version: CE tagged



Recommended for:

A Models
C Models
HS Models

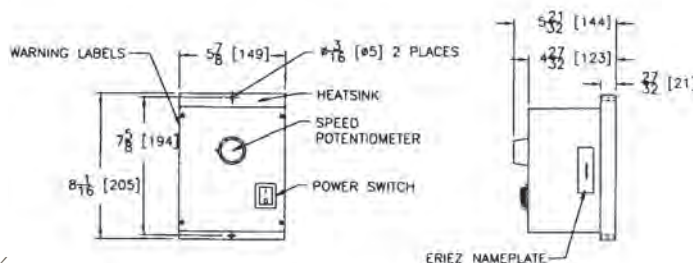

24 UniCon NEMA 12 (IP54) Control

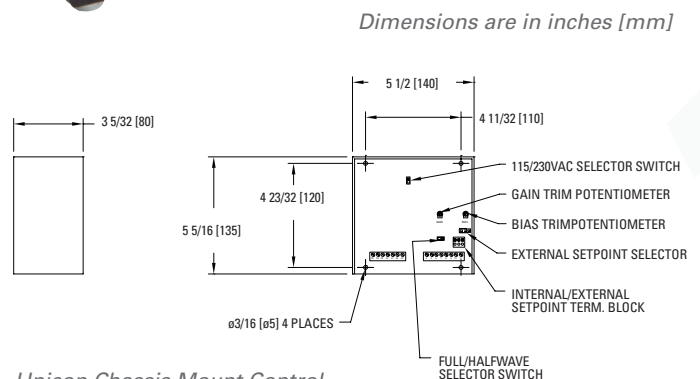

UniCon Chassis Mount Control

UniCon HC Control (High Current)

FEATURES:

- Additional features to UniCon model
- Models available from 5 to 40 amps
- 25 and 40 amp base models
- 115, 230, 380, 460 and 575 volts
- Accept 4-20 MA signal
- Remote on/off capability
- Bias and Gain pots
- Auto/Manual selector switch
- Chassis mount and NEMA 4 enclosures standard
- Closed-Loop operation with accelerometer available to maintain tray deflection UL, CUL and CE tagged



Recommended for:

- A Models
- C Models
- HS Models

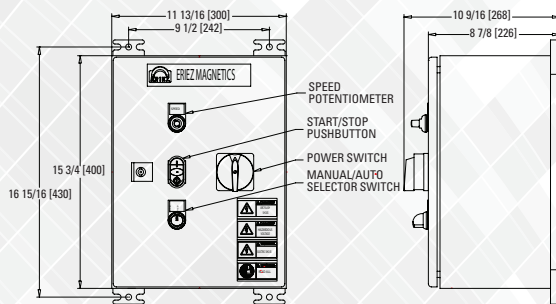

NEMA 4 UniCon HC 5-25 Amp Models

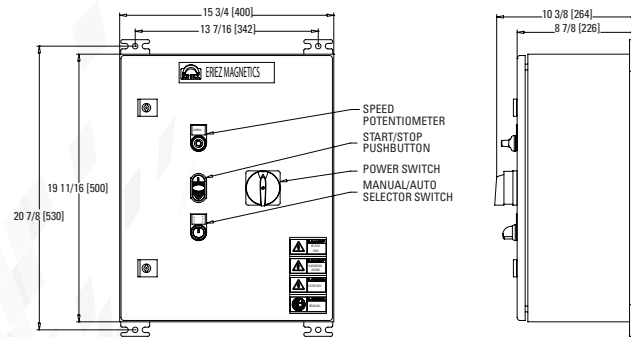

NEMA 4 UniCon HC 30-40 Amp Models

G-Series Control

FEATURES:

- Full range of customized feeder controls
- 115 and 230 volts
- Nema 12 (IP54) enclosure standard
- Accept 4-20 MA signal
- Remote on/off capability
- Dual rate-of-feed available
- Panel mount version
- Closed-Loop operation with accelerometer available to maintain consistent tray deflection
- Standard units are CE tagged
- ESA evaluation and tagging for Canada available
- Digital display
- 12 amp maximum for NEMA 12 version and 15 amp maximum for NEMA 4x and panel mount



Recommended for:

- HD Models

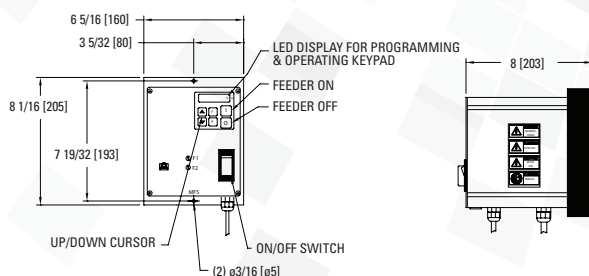

G Series NEMA 12 (IP54) Control

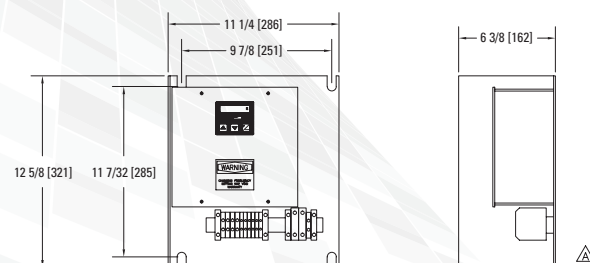

G Series Panel Mount Control

Dimensions are in inches [mm]

Spare Parts

Drive Unit Spare Parts Kits

Spare Parts kits are in stock and available for our 15A thru 76 model compact vibratory feeders. These kits include everything needed to rebuild a compact feeder drive in a typical shut-down/emergency situation. Eriez configured the kits to accommodate 115-volt operation for the 15A thru 66 models and 230 volt for the 76 models.

Kits Include:

- Corded electrical assembly
- Diaphragm
- Shock mounts
- Elastomers (HS and HD versions)
- Tuning springs (front and black)
- Spacers
- Associated hardware



Drive Assembly



Fully Assembled Drive Unit



Spring Assembly Removal

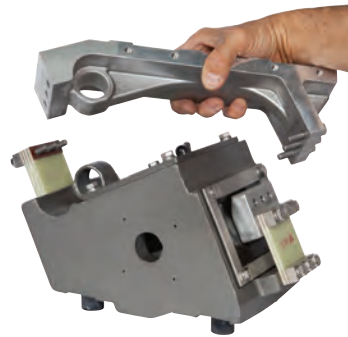

Tray Mount Top Bar is Removed from the Drive & Springs



Electromagnetic Drive Assembly Lifts Out of the Housing

Other Resources



Parts



Parts Kits

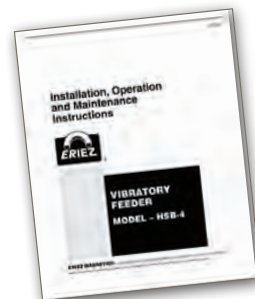

Instruction Manuals



Instructional Videos



Preliminary Vibratory Specification Sheet

Contact Information

DATE: _____
 CUSTOMER NAME: _____
 ADDRESS: _____
 CITY: _____ STATE: _____ ZIP: _____
 CONTACT: _____ PHONE: _____
 TITLE: _____ EMAIL: _____

Application Details

MATERIAL SUPPLIED FROM: _____ NO. OF UNITS: _____
 FEEDER DISCHARGES TO: _____
 MATERIAL TO BE HANDLED: _____
 BULK DENSITY: _____ PRODUCT TEMP: _____
 CAPACITY: _____ AMBIENT TEMP: _____
 PARTICLE SIZE: _____ ABBRASIVE: _____
 ANGLE OF REPOSE: _____ MOISTURE %: _____

Equipment Design

OPERATING VOLTAGE: VOLTAGE: _____ HZ: _____
 IS FEEDER CYCLED ON/OFF: NO: YES: HOW OFTEN: _____
 DRIVE LOCATION: BELOW TRAY: _____ ABOVE TRAY: _____
 MOUNTING: BASE: _____ SUSPENSION: _____
 TRAY SIZE: WIDTH: _____ LENGTH: _____ DEPTH: _____
 TRAY TYPE: OPEN: ENCLOSED: TUBE:
 OTHER: _____
 IF ENCLOSED: INLET INFO: OUTLET INFO: _____
 TRAY MATERIAL: MILD STEEL: 304 SS: OTHER:
 SANITARY CONSTRUCTION: NO: YES: DESCRIPTION: _____

Other Requirements

SCREEN: NO: YES: DESCRIPTION: _____

Control Requirements

CONTROL REQUIRED: NO: YES: NEMA ENCLOSURE TYPE: 1 12 4 4X SS
 SIGNAL FOLLOWING: NO: YES: IF YES, 4-20 MA OR 0-10 VDC: _____

Other Features



GLOBAL LEADER IN SEPARATION TECHNOLOGIES

HEADQUARTERS

2200 Asbury Road • Erie, PA 16506-1402 U.S.A.

1-814-835-6000 • eriez@eriez.com

www.eriez.com



AUSTRALIA

Epping, Victoria
+61 3 8401 7400



BRAZIL

Belo Horizonte, Minas Gerais
55 31 3281 9108



CANADA

Delta, British Columbia
+1 604-952-2300



CHILE

Las Condes, Santiago
56 2 29523400



CHINA

Qinhuangdao and Tianjin
86-22-8390-4608



GERMANY

Recklinghausen
+49 (0)160 94179313



INDIA

Athipet, Chennai
91-044-2652-5000



JAPAN

Urayasu, Chiba
+81-47-354-6381



MEXICO

Querétaro, Tlalnepantla
52 555 321 9800



PERÚ

Surco, Lima
51 1 719 4150



SOUTH AFRICA

Boksburg, Gauteng
27-011-444-9160



UNITED KINGDOM

Bedwas, Caerphilly
44-29-2086-8501



UNITED STATES

Erie, Pennsylvania
1-814-835-6000



Note: Some safety warning labels or guarding may have been removed before photographing this equipment.
Eriez, Eriez Flotation and Eriez Magnetics are registered trademarks of Eriez Manufacturing Co, Erie, PA